

BECKETT CF800

COMMERCIAL OIL BURNER

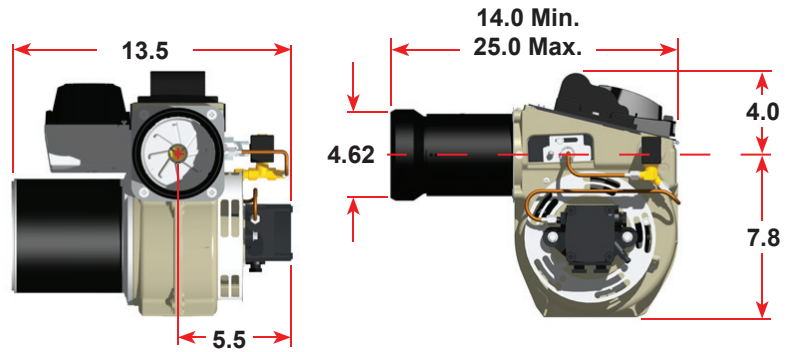

Overall Dimensions



Specifications

Fuels:	U.S. #1 or #2 Fuel Oil only (ASTM D396) Canada #1 Stove Oil or #2 Furnace Oil only
Firing range:	CF800: 3.00 to 8.00 GPH
Motor:	1/3 HP 3450 RPM 120/60 hz standard 4.8 amps @ 120 VAC
Igniter:	120V/14,000V
Housing:	Cast aluminum
Fuel unit:	100 - 200 PSIG
Oil nozzle:	45° - 70° solid
Shipping weight:	55 lbs.

Sequence of Operation

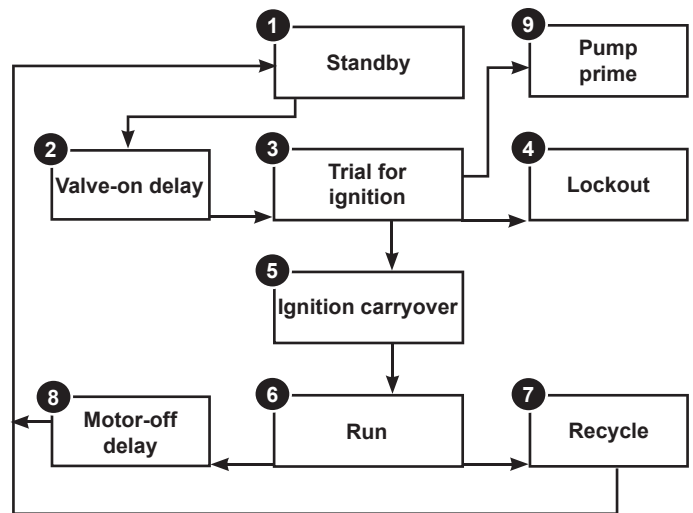

One-pipe oil flow with "B" pump

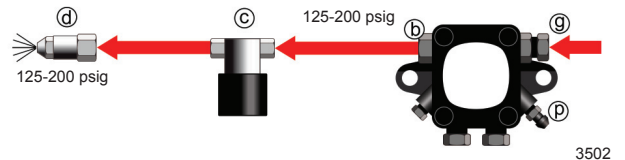

Two-pipe oil flow with "B" pump

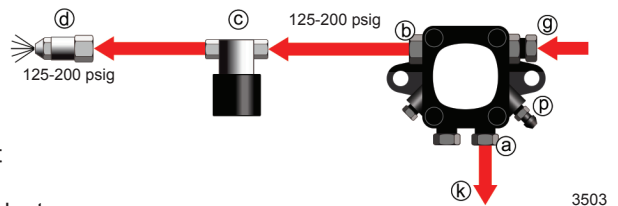

Legend

- a Return port
- b Nozzle port
- c Oil valve
- d Nozzle & adapter
- g Inlet port
- k Return line to oil tank
- p Air bleed valve

Features

S - Standard	O - Optional	
	S	On/Off
	O	Air Proving Switch
	S	Direct Spark Ignition of Main Flame
	O	Flame Safeguard with UV Sensor or Light Sensor
	O	Customized Electrical Cabinet
	S	UL/CUL - CSD1 - XL GAPS ¹
	O	FM
	O	IRI (old standard)

¹ Some regional codes are standard; some require additional options.

Typical Wiring

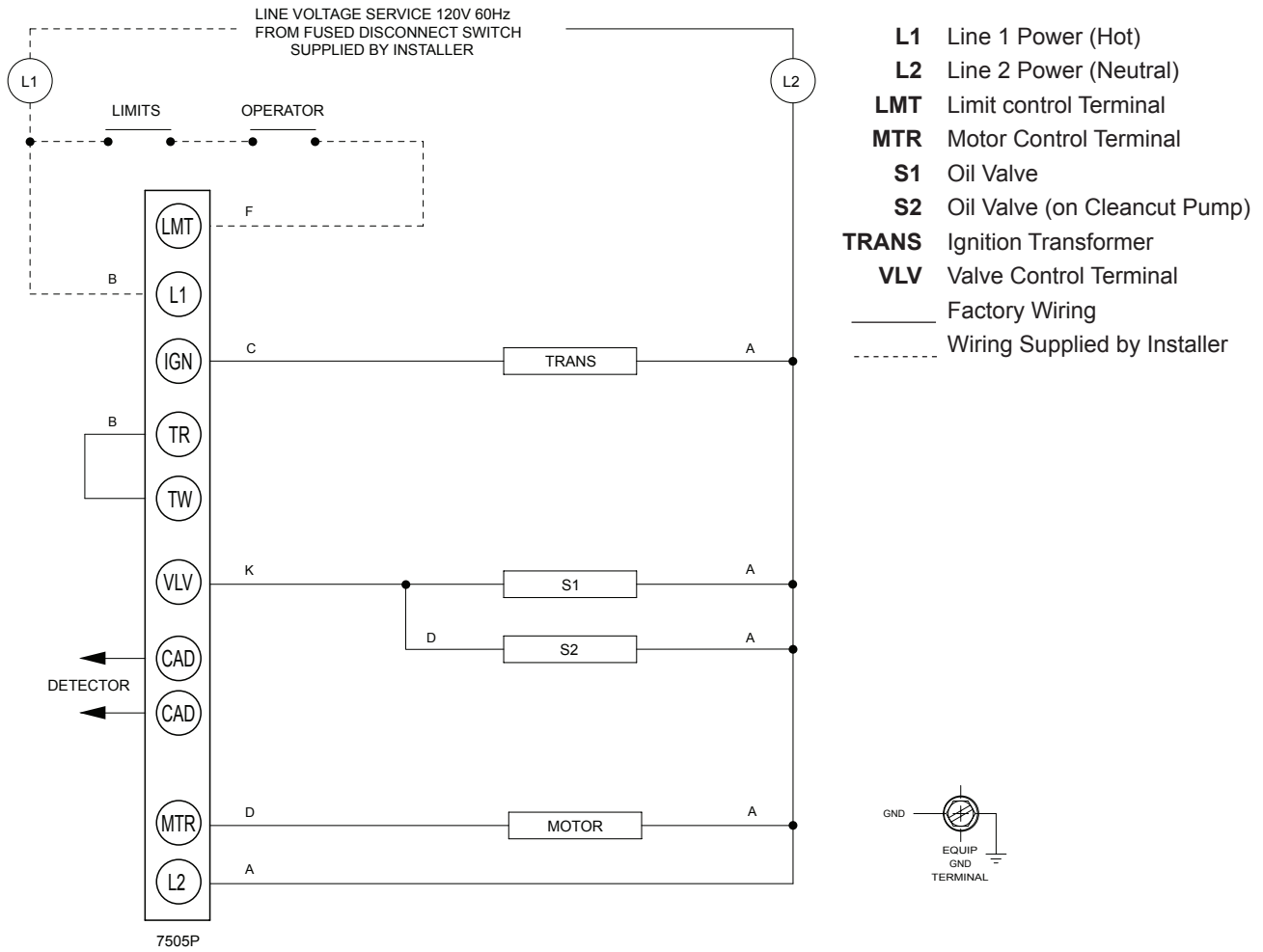

Combustion Chamber Dimensions

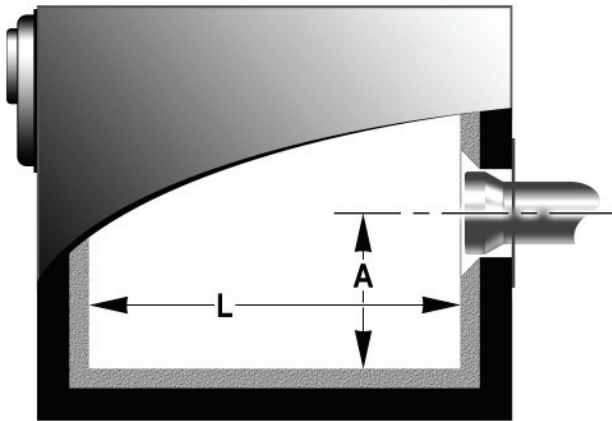

1405

Firing Rate	Minimum Dimensions			
	(with damper)		(without damper)	
	A	L	A	L
1.75 to 3.00 gph	7.5"	18.0"	8.0"	19.0"
4.00 gph	8.0"	21.0"	9.5"	23.0"
5.00 gph	9.0"	23.0"	10.5"	30.0"
6.00 gph	10.0"	28.0"	11.5"	40.0"
7.00 gph	11.0"	34.0"	12.0"	46.0"
8.00 gph	14.0"	38.0"	14.0"	51.0"